

Profoto®

Softlight Reflectors

Modular
Light
Shaping
Tools



“When I think about Profoto,
the most important thing to me is
that it is precise, very precise.”

— Diego Uchitel



“When I think about Profoto, the most important thing to me is that it is precise, very precise. When I am either working with a very well known celebrity or a high caliber model, once these people are on the set, the last thing they want to put up with is things not working correctly. If I tell my assistant to click it down one sixth, Profoto does it. Everytime.

I like to shoot in a romantic kind of painterly way. It has become my style. And, I most enjoy using one light. The Profoto beauty dish gives me a certain kind of light I very much like. It is the spread, the softness, the contrast, the overall feeling which I am most comfortable with. I use it for a great deal of my work.

Often, I use mixed light, such as flash and daylight balance. I think it is an interesting effect. I like how it works just to be able to control the background as a more of a surreal part of the photograph, to make the person stand out. Sometimes I will experiment with balance until the subject seems to be jumping off the photograph.”

–Diego Uchitel

Softlight Reflectors direct light with soft shadows

The white Softlight Reflector also known as “The Beauty Dish” gives a soft, yet easily focused light. Meant to provide character lighting in portrait photography, the Softlight is superb for a wide variety of uses. From product to fashion photography, the softlight reflector is an excellent light source whenever a soft yet direction light is preferred. It is a distinctive alternative to ordinary Softbox.

The center disc that blocks out the direct light can be replaced by an semi-opaque glass disc to create a center hot spot and eliminates the donut-hole effect in specular highlights. When used with a honeycomb grid you get a soft, toned-down edge-lighting effect, with 10° coverage with the silver, and 25° with the white reflector for more directed light.

Light Distribution Pattern
Guide number in feet at 100 ASA

ComPact 300	52	72	105	148	210	295	420
ComPactPlus 600	72	105	148	210	295	420	590
ComPactPlus 1200	105	148	210	295	420	590	840
Acute 12 1200Ws	105	148	210	295	420	590	840
Acute 24 2400Ws	148	210	295	420	590	840	1181
Pro-7a/s/b 1200	130	180	250	360	460	660	1030
Pro-7a/s 2400	180	250	360	460	660	1030	1410
D4 1200Ws	105	148	210	295	420	590	840
D4 2400Ws	148	210	295	420	590	840	1181

Softlight / White – 65° beam

Designed to give a wide, uniform and soft light and shadow definition. The gradual fall-off makes it perfect for close-up beauty photography.

Softlight / White with Grid – 25° beam

This permits light to pass straight out, but extinguishes the edge light steplessly, with very soft shadow definition. Suitable for character key lighting for portraiture. The beam pattern is very similar to the SoftLight/Silver, but is two stops less efficient.

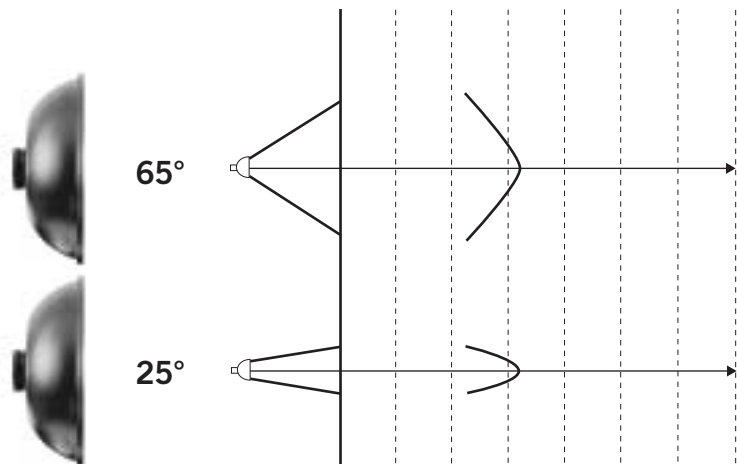

Softlight Reflector and Accessories

Cat#	Int'l#	
505-507	(10 06 08)	Softlight White Reflector
505-541	(10 06 09)	Honeycomb Grid for Softlight Reflectors
505-542	(90 06 33)	Glass Kit, includes Frosted Glass Disc and Parts (replacement)
505-543	(10 07 04)	Semi-opaque Glass Disc for Center of Softlight Reflector

